

**EXPLORE
THE IMPOSSIBLE**



**THE ALL-NEW
THAR**

**THE ALL-NEW
THAR**

Mahindra & Mahindra Ltd., Automotive Sector, Mahindra Tower, 3rd Floor, Akurli Road, Kandivali (E), Mumbai - 400101, India.
Tel: 022-2884 9588, Fax: 022-28468522 | <http://auto.mahindra.com/suv/thar>

All features mentioned are not available on all models. Accessories shown are not a part of the standard equipment. Performance figures may differ in conditions other than test conditions. Vehicle body colour may differ from the printed photograph. In view of our policy of continuously improving our product, we reserve the right to alter specifications or design without prior notice and without liability. We reserve the right to add or delete any feature or elements in any of our models without any prior notice or without any liability. Please check model details with your nearest dealer. Android Auto™ and Apple CarPlay™ are compatible with Android™ and IOS mobiles devices respectively.

HERE IS WHERE IMPOSSIBLE BEGINS

They say, once in every generation comes something that changes the very course of history.

Say hello to the All-New Thar.

The Thar's iconic design gets a contemporary spin in its new avatar giving it an uber-cool and neo-retro appeal.

Performance is the name of the game and with the legendary capability synonymous with its predecessors, the All-New Thar rewrites all rules out there.

Coupled with state-of-the-art technology and new-age features that make city rides just as exhilarating as your off-roading escapades.

Enough said, Are you ready to explore the impossible?



WHEN RETRO MEETS NEW AGE SUAVE.

Ask a child to draw a car and what you'd get is the iconic form factor that's the Thar's identity. Something that has remained unchanged since day one and always will.



TIMELESS GOOD LOOKS

The All-New Thar retains its iconic front profile, with its distinctive front grille paired with minimal round headlamps. One look and you'll know what love at first sight really means.

CAPTIVATING LED DRLs

The All-New Thar sports a new pair of fender-mounted daytime running LED lamps that give it extra visual oomph from the front.

A BEAST OF A BUMPER

The purpose-built bumpers do away with the paint on their outboard ends to prevent scratches while in the city or out in the wild.

STYLE MEETS STRENGTH

The All-New Thar marries unmatched performance with an impressive sense of style, thanks to its Deep Silver 45.72 cm R18 alloy wheels.

YOUR OWN PRIVATE COCOON

Prefer your own private cocoon? Here's the hard-top variant which is designed to meet the refinement levels that'll make your drive as smooth as floating through clouds.

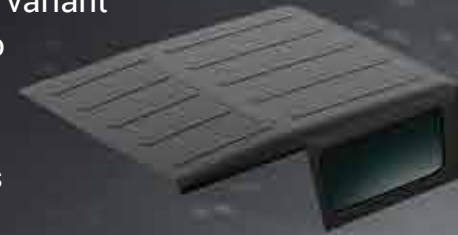

WIND IN YOUR HAIR

Opt for the Manual Convertible Top variant of the All-New Thar to enjoy your expeditions with that wind-in-the-hair feeling. It's the ultimate expression of flamboyance while letting you be one with the outdoors.



RETRO IS BACK

The All-New Thar's LED tail lamps enhance visibility and their stylish retro look is sure to catch eyeballs anywhere you go.



EMPEROR OF ALL TERRAINS.

Ragged, uncompromising, tough – these are some of the words used to describe the Thar's playground.





LEFT FOOT ON LEAVE

Get your new Thar to do some of the heavy lifting. With its new 6-Speed Automatic Transmission, shifting through gears is now a breeze. Impossible terrains will just feel like a walk in the park.



GEAR UP. REVHEADS

If you've got a wild streak and fancy pushing the All-New Thar to its limits, the 6-Speed Manual Transmission is the one for you. Enjoy the rush of power in your hands.

D117



LET THE POWER PLAY BEGIN

Mahindra's next-generation D117 and mHawk 130 Diesel Engines ooze torque and raw power, ready to do your bidding even on the toughest mountain inclines. From great to greatest, there's no terrain that this diesel-powered behemoth can't conquer.

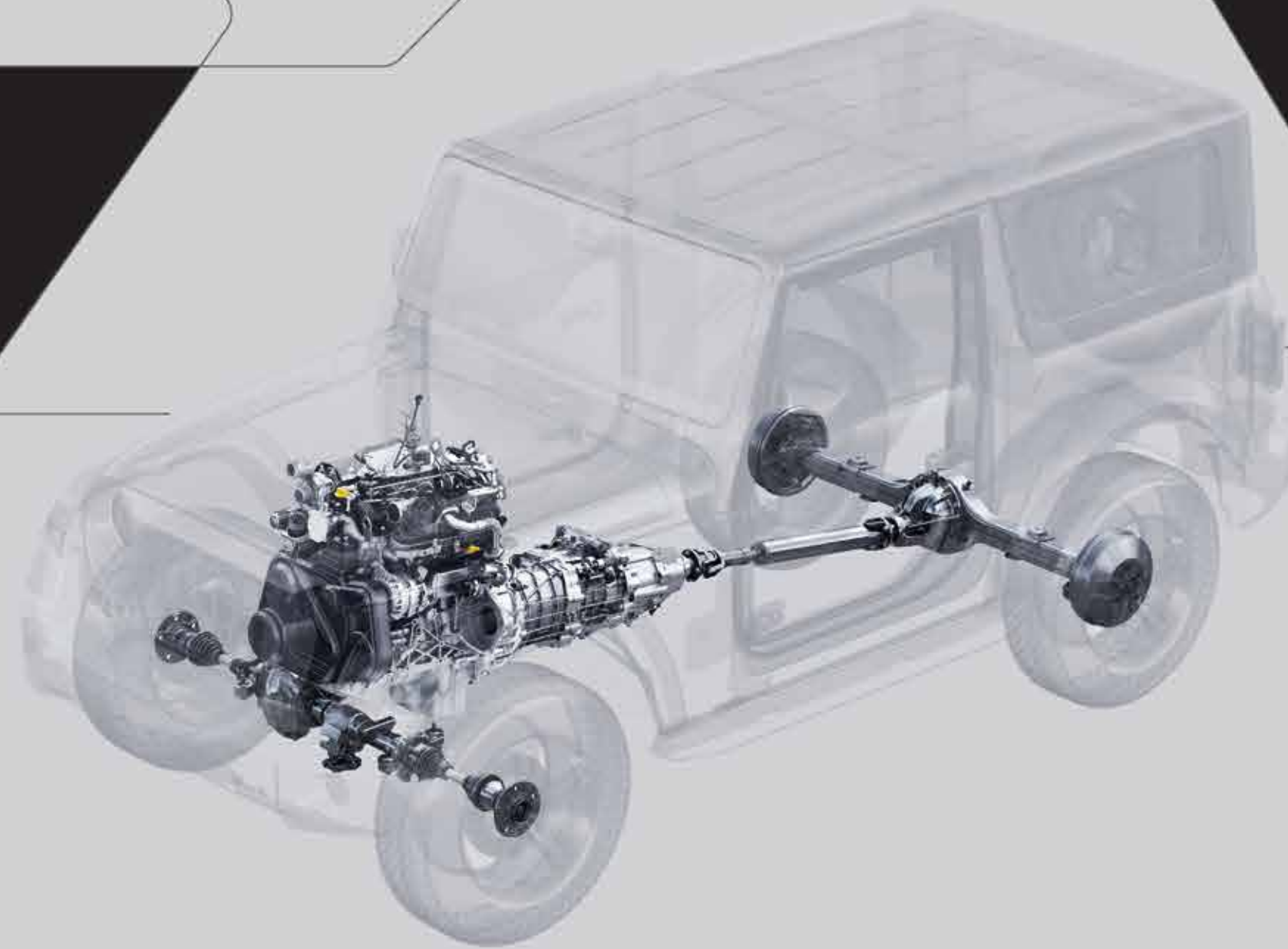

THE THOROUGHbred STALLION

The all-new mStallion 150 is Mahindra's first-ever TGD Petrol Engine – a spirited, powerful and torquey motor that's perfect for revheads everywhere. The game is about to change with this beast.



SWITCH IT UP

The new Thar boasts of a segment-first electric driveline disconnect function for a seamless transition from 4x2 to 4x4 mode

ALL-TERRAIN SUSPENSION

Enjoy superior off-roading traction and smooth handling on paved roads with the Thar's All-New suspension with a combo of Independent Front Suspension and Multi-Link Rear Suspension.



GO ANYWHERE

Seamlessly switch into 4x4 mode with the manual shift 4x4 Transfer Case with Low Ratio with a manual shifter that's full of old-school charm.

TRUE BLUE SUV CONSTRUCTION

The All-New Thar's authentic 3rd Generation Body-on-Frame Construction chassis can handle absolutely any terrain without breaking a sweat.

GET A GRIP

Whether there's road or no road, it's not a problem for the All-New Thar's all terrain 255/65 R18 tyres that offer great comfort and grip

NO SLIP UPS

Advanced Electronic Brake Locking Differential that electronically locks up all axles in slippery conditions for maximum traction



**AS
PREMIUM
INSIDE AS
LEGENDARY
OUTSIDE.**

The all-new interiors have everything it takes to make your ride as comfortable and fun as possible.



GLUED TO YOUR SEAT

Sporty front seats with body-hugging contours to keep you comfortably planted even during the bumpiest rides.

BACK TO THE FRONT

Front-facing rear seats with 50:50 split that let rear seat passengers travel comfortably for long distance and fully fold to fit in extra luggage.

THE HEIGHT OF SEATING

Drive comfortably while being seated at your preferred height with the new Thar's height adjustable driver seat.

NO DOOR THRILLS

Out on an off-roading adventure? Experience the thrills of driving without doors as you can remove and fix the doors on the All-New Thar with super ease.

LOCK AND LOAD

With the All-New Thar's Central Locking Mechanism along with its Remote Flip Key, keeping your vehicle safe is an absolute breeze.

PARTY ON THE ROOF

With the All-New Thar's Roof Mounted Speakers, the concert's on 24x7, as you groove to your playlist even while wading through knee-deep water.



RETRO COOL MEETS NEW TECH

The All-New Thar is loaded with state-of-the-art technology, helping you stay in control of your ride at all times and stay connected with the outdoors.



TOUCH AND GO

Navigate the terrain or set the mood for your trip with the new waterproof Touchscreen Infotainment System with Android Auto, Apple CarPlay and USB.

Get all the info about your Thar and your trip with just a few touches.

THE SCIENCE OF ADVENTURE

Monitor all your vital stats and information through the Adventure Statistics System equipped with an altimeter, a compass and a roll & pitch meter. Now you're in total control of your Thar from the inside no matter how bad conditions are outside.

PLAY IT SMART

Link your Thar to your smartwatch or phone through the Blue Sense App to access all your devices effortlessly. Giving you even more power in your hands.





ALWAYS FULLY INFORMED

Keep an eye on all essential ride-related information with the All-New Thar's revamped TFT Multi-Information Display in the cluster. The super convenient display gives you all the info you'll need in a matter of seconds.

KEEP THE PRESSURE ON

The All-New Thar keeps on monitoring the pressure levels of all the four wheels plus the spare with its Tyre Pressure Monitoring System. So that you're always informed about the condition of your tyre, thereby making you and the Thar safe and secure.





TAKE ON THE IMPOSSIBLE WITHOUT FEAR.

The adrenaline-packed adventures you embark on need an equally safe and secure partner, and the All-New Thar is just that. So, buckle up inside the All-New Thar and take on the impossible without fear



YOU'RE IN STABLE HANDS

Enjoy taking sharp turns without fear of nasty tumbles with the All-New Thar's ESP with Rollover Mitigation Technology



PREPARED FOR EVERYTHING

The All-New Thar meets global crash safety norms and keeps passengers away from harm during collisions with its crash-safety compliant bodyshell.

YOUR PROTECTIVE SHIELD

Built-in interior Roll Cage and 3-Point Seatbelts add structural rigidity to the Thar and safeguard their passengers during a rollover or accident.

CUSHIONED FROM IMPACT

The All-New Thar sports Dual Front Airbags and ABS to protect passengers and safely manoeuvres the vehicle out of the trickiest of situations.

NO MORE UPHILL STRUGGLES

The new Thar comes with a Hill Hold and Hill Descent Control System to assist you and achieve a controlled uphill or downhill journey.

SLEEP LIKE A CHILD

With its ISOFIX Child Seat Mounts, the all-new Thar keeps your little ones snug and safe through all your explorations. So, take them on your adventures and give them a dose of your wild side without any worry at all.

5 EXCITING COLOURS

DEEP FOREST



EVEREST WHITE



NAPOLI BLACK



RED RAGE



GALAXY GREY





YOUR THAR. YOUR WAY.

Make your Thar as unique as you are with a wide variety of accessories.
Get a preview of your Thar with all the personalization options you crave for.

DECKED UP TO IMPRESS

Thar offers over 120 accessories ranging from hardcore off-roading to everyday essentials designed in house by the Mahindra Design Studio and the engineering team at Mahindra Research Valley. So, you can customize your All-New Thar with genuine accessories without having even a shadow of doubt in your mind.

Check out the accessories and merchandise catalogue to get ideas on how to personalise your Thar. Once you have decided, you are only a few steps away from seeing a 360-degree preview of your All-New personalised Thar.



Technical Specifications	AX OPT		LX	
Engine (Diesel)				
Engine	D117 CRDe	mHawk 130 CRDe	D117 CRDe	mHawk 130 CRDe
Engine Capacity (cm3)	1497	2184	1497	2184
Max Power (kW @ r/min)	87.2@ 3500	97 @ 3750	87.2@ 3500	97 @ 3750
Max Torque (Nm @ r/min)	300 @ 1750 - 2500	300 @ 1600-2800	300 @ 1750 - 2500	300 @ 1600-2800
Transmission (Diesel)				
Transmission Type	6-Speed Manual	6-Speed Manual	6-Speed Manual	6-Speed Manual / 6-Speed Torque Converter Automatic
Drive	Rear Wheel Drive (RWD)	Manual Shift Part-Time 4WD with High & Low Reduction Gear	Rear Wheel Drive (RWD)	Manual Shift Part-Time 4WD with High & Low Reduction Gear
Front Axle	NA	Semi-Floating with 4.3:1 Final Drive	NA	Semi-Floating with 4.3:1 Final Drive
Rear Axle	Banjo beam with 4.88:1 Final Drive	Banjo beam with 4.3:1 Final Drive	Banjo beam with 4.88:1 Final Drive	Banjo beam with 4.3:1 Final Drive
Steering	Rack & Pinion Hydraulic Power Steering			
Hub Lock	NA	Automatic	NA	Automatic
Engine (Petrol)				
Engine	mStallion 150 TGD <i>i</i>		mStallion 150 TGD <i>i</i>	
Engine Capacity (cm3)	1997		1997	
Max Power (kW @ r/min)	112 @ 5000		112 @ 5000	
Max Torque (Nm @ r/min)	300 @ 1250-3000		300 @ 1250-3000 (with MT) 320 @ 1500-3000 (with AT)	
Transmission (Petrol)				
Transmission Type	6-Speed Manual		6-Speed Manual / 6-Speed Torque Converter Automatic	
Drive	Manual Shift Part-Time 4WD with High & Low Reduction Gear		Manual Shift Part-Time 4WD with High & Low Reduction Gear (with MT & AT) or Rear Wheel Drive - RWD (with AT)	
Front Axle	Semi-Floating with 4.3:1 Final Drive for 4WD, NA for RWD		Semi-Floating with 4.3:1 Final Drive for 4WD, NA for RWD	
Rear Axle	Banjo beam with 4.3:1 Final Drive	For 4WD and NA for RWD	Banjo beam with 4.3:1 Final Drive	For 4WD and NA for RWD
Steering	Rack & Pinion Hydraulic Power Steering			
Hub Lock	Automatic for 4WD and NA for RWD			

Technical Specifications	AX OPT		LX	
Suspension, Brakes & Wheels				
Front Suspension	Independent Double Wishbone Front Suspension with Coil Over Damper & Stabiliser Bar			
Rear Suspension	Multilink Solid Rear Axle with Coil Over Damper & Stabiliser Bar			
Brake Specifications	Vaccum Assisted Dual Hydraulic Circuit with Tandem Master Cylinder			
Front Brakes	303 mm Disc			
Rear Brakes	282 mm Drum			
Wheels & Tyres	245/75 R16 Tubeless All-Terrain Tyres		255/65 R18 Tubeless All-Terrain Tyres	
Dimensions				
Length (mm)			3985	
Width (mm)	1820	1820	1820	1820
Height (mm)	1850	1844	1855	1844 (Hard Top)
Wheelbase (mm)			2450	
Front Track (mm)			1520	
Rear Track (mm)			1520	
Ground Clearance (mm)	226		226	
Approach Angle	41.2 degree		41.2 degree	
Departure Angle	36 degree		36 degree	
Rampover Angle	26.2 degree		26.2 degree	
Water Wading Depth (mm)			650	
Seating Capacity	4-Seater (Front: 2 Forward-Facing, Rear: 2 Front-Facing)			
Fuel Tank Capacity (litre)	D117 CRDe: 45, mHawk 130 CRDe: 57, mStallion 150 TGD <i>i</i> : 57			
Diesel Exhaust Fluid Tank (litre)	20 (Applicable only for CRDe engine)			

Features	AX OPT	LX
Design		
Top Option	Diesel 4WD: Convertible OR Hard Top Diesel RWD: Hard Top Petrol 4WD: Convertible Top	4WD: Convertible or Hard Top RWD: Hard Top
All-Black Bumpers	Y	✓
Bonnet Latches	✓	✓
Vertical Slats on the Front Grille	Black Finish	Black Finish
Wheels	R16 Steel Wheels	R18 Deep Silver Alloy Wheels with Thar Branding
LED Tail Lamps	✓	✓
Front Fog Lamps	✗	✓
Wheel Arch Cladding	✓	✓
Side Foot Steps	Tubular Steel	Moulded
Fender-mounted Radio Antenna	✗	✓
Tailgate mounted Spare Wheel	✓	✓
Comfort & Convenience		
Seat Upholstery	Vinyl	Fabric
Tilt Adjustable Steering Wheel	✓	✓
Cruise Control	✗	✓
Steering Mounted Audio & Phone Controls	✗	✓
Tip & Slide Mechanism in Co-Driver Seat	✓	✓
Reclining Mechanism, Adjustable Headrests, 50:50 Split in Rear Seat	✓	✓
Height Adjustable Driver Seat	✓	✓
Centre Roof Lamp	✓	✓
12V Accessory Socket	✓	✓
Lockable Glovebox	✓	✓
Utility hook in backrest of co-driver seat	✗	✓
Central Locking	✓	✓
Remote Keyless Entry	✓	✓
Rear Demister	With Hard Top	With Hard Top
Dashboard Grab Handle for Front Passenger	✓	✓
Bottle Holder in Front Doors	✓	✓
Tool Kit Organiser	✓	✓
Illuminated Key Ring	✓	✓
Manual Day-Night IRVM	✓	✓

Features	AX OPT	LX
Technology		
HVAC	✓	✓
Electrically Operated HVAC Controls	✗	✓
17.8 cm Touch Screen Infotainment System with Android Auto & Apple CarPlay	✗	✓
4 Speakers + 2 Tweeters	✗	✓
MID Display in Instrument Cluster	Monochrome	Coloured
Adventure Statistics	✗	✓
Tyretronics (Tyre Pressure Monitoring System)	✗	✓
Tyre Direction Monitoring System	✗	✓
BlueSense App Connectivity	✗	✓
Follow-Me-Home & Lead-Me-To-Thar Lamps	✗	✓
One-Touch Lane Change Indicator	✓	✓
Voice Commands & SMS Read-Out	✗	✓
Rear Parking Sensors	✓	✓
ORVM Adjustment	Manual	Electric
Power Windows in Front Doors	✓	✓
Off-Road Essentials		
Electric Driveline Disconnect on Front Axle in 4WD Variants	✓	✓
Electronic Brake Locking Differential for RWD	in D117 RWD only	✓
Advanced Electronic Brake Locking Differential for 4WD	✗	✓
Mechanical Locking Differential	✗	Optional in mHawk 130
Washable Floor with Drain Plugs	✓	✓
Welded Tow Hooks in Front & Rear	✓	✓
Tow Hitch Protection	✓	✓
Safety		
ESP with Roll-over Mitigation	in D117 RWD only	✓
Hill Hold & Hill Descent Control	in D117 RWD only	✓
ABS with EBD & Brake Assist	✓	✓
Dual Airbags	✓	✓
Seat Belt Reminder	✓	✓
ISOFIX Child Seat Mounts on Rear Seats	✓	✓
Roll Cage	✓	✓
3-Point Seat Belts for Rear Passengers	✓	✓
Snow Chain Provision for Tyres	✓	✗
Speed Sensing Front Door Locks	✗	✓
Panic Braking Signal	✓	✓
Vehicle Over-speed Warning	✓	✓
Passenger Airbag Deactivation Switch	✓	✓